

Before the  
**FEDERAL COMMUNICATIONS COMMISSION**  
Washington, DC

WT Docket No. 12-268

In the Matter of  
Policies and Rules Needed to Attain  
A Spectrally Efficient  
DTV Band

**SPECTRALLY EFFICIENT UHF and VHF DTV BROADCASTING**

by Oded Bendov

Email: [oded@tvantenna.tv](mailto:oded@tvantenna.tv)  
February 06, 2013

## **1. QUALIFICATIONS**

My professional career, spanning 45 years, has been the design and analysis of TV transmission systems: transmission, propagation and reception. After receiving a Ph.D. from Northwestern University I started as a Principal Engineer with RCA. Before retiring to start my own consulting company in 2003 I was Sr. VP and Chief Scientist of Dielectric Communications. I am the 46<sup>th</sup> (2005) recipient of the NAB Television Engineering Achievement Award. A more detailed professional biography and my recently published papers are available on my firm's website, [www.tvantenna.tv](http://www.tvantenna.tv)

## **2. INTRODUCTION**

The transition from analog to digital television and the new technologies available to the designers of modern broadband transmitters and receivers emphasize the potential for far more efficient use of the spectrum in simultaneously minimizing the occupied frequencies while maximizing the payload distribution over a defined service area.

The time has come for all stakeholders to create a spectrally efficient DTV band, one that is free of the shackles of old: taboo channels, nonlinear receivers with front-end tunable ("can") filters and propagation algorithms that over-predict the incident signal level well beyond the radio horizon. Now the FCC should focus on predicting the decodable payload, the real measure of service where it can be delivered—only inside the radio horizon.

As Exhibit A shows, contiguous transmission on channels 14-37 and 7-13 is possible, subject to some modified rules and regulations that mandate minimal receiver performance and set the radio horizon as the limit of protected service. The two DTV bands, contiguous channels 7-13 and 14-37, are more than adequate to accommodate all TV stations. Allowing for flexible modulation, DTV transmissions will be decoded by hand-held devices, with graceful degradation of the payload, up to the radio horizon.

## **3. EXECUTIVE SUMMARY**

Spectrally efficient DTV transmission and reception on contiguous VHF channels 7-13 and contiguous UHF channels 14-37 is possible given the state-of-the-art of broadband receiver technologies, subject to new rules and regulations within the jurisdiction of the Federal Communications Commission.

The new rules and regulations must require the following:

- Replacement of the current coverage area definition, a relic of analog television, with a service area definition applicable to digital television.
- Mandated minimum performance of linearity and sensitivity for DTV receivers.
- Mandated SNR-controlled AGC to replace the broadband, signal power-controlled AGC at the receiver.

- DTV broadcasters permitted to experiment with COFDM modulation aimed at improving the robustness of deliverable payload.

The Commission has established rules and regulations for DTV transmitters and propagation models but not for the weakest link in the digital DTV chain—the receiver<sup>1</sup>. Without adding mandated minimum linearity performance to DTV receivers, maximum spectral efficiency in the DTV band will not materialize.

The attached Exhibit A, a thorough analysis of 3rd order interference in contiguous DTV channel environment, supports this summary. The FCC laboratory in cooperation with set manufacturers can verify the results presented in Exhibit A.

#### **4. THE COMMISSION SHOULD DEFINE THE DTV SERVICE AREA BY ITS TRUE LIMIT, THE RADIO HORIZON**

Two propagation models are in use by the FCC to designate the coverage contour of DTV stations: the original F(50,90) and more recently, the Longley-Rice LR(50,90). Why two different propagation algorithms where only one is needed? In fact, neither comes close to predicting coverage of the incident signal<sup>2</sup>, much less the service (decodable payload) of DTV.

It is well established that reliable reception of analog and digital TV signals beyond the radio horizon is impossible and unnecessary. Within a short distance beyond the radio horizon the signal drops 30dB so if that desired signal level is -60dBm at the horizon, it's interference level beyond the horizon would be -90dBm, a value close to the noise floor of actual receivers with their antenna connected. The two current prediction algorithms have thus created vast swaths of protected geographical areas by unusable DTV signals.

The Commission should declare the radio horizon as the limit of protected DTV service and set a minimum signal level at the horizon sufficient for reliable delivery of the payload. Cochannels within the horizon should be permitted to negotiate with cochannels beyond the horizon a higher radiated power than the minimum level set by the Commission. This should be the first step toward achieving spectral efficiency.

---

<sup>1</sup> The FCC mandated minimum Noise Figure for TV receivers when UHF receivers were added to VHF receivers. Multipath and interference were not considered sufficiently important in analog TV because they only affected video quality. Interference protection was dealt with by assigning Taboo channels and by wide geographic spacing between cochannels, as there was no need for an efficient use of the spectrum. Sixty years later, those considerations are irrelevant for DTV.

<sup>2</sup> O. Bendov, "***DTV Coverage and Service Prediction, Measurement and Performance Indices***," IEEE Transactions on Broadcasting, September, 2001. Can be downloaded from [www.tvantenna.tv](http://www.tvantenna.tv).

Each of Figures 1-4 demonstrate the gross over-prediction, to beyond the radio horizon, in flat and mountainous terrain, for UHF and VHF DTV stations.

## **5. THE COMMISSION SHOULD MANDATE MINIMUM LINEARITY FOR DTV RECEIVERS**

As shown in Exhibit A, a major obstacle to the transmission of contiguous DTV channels, a requirement for spectral efficiency, is the inherent non-linearity of DTV receivers and in particular, 3<sup>rd</sup> order intermodulation and crossmodulation products generated by that non-linearity<sup>3</sup>.

In recent years, technological advances have made the production of linear, consumer-grade DTV receivers simpler than was possible when analog TV was introduced. For competitive reasons, manufacturers of TV sets do not publish linearity specifications, but that performance parameter can be estimated from measurements. Some DTV converter boxes, described in Exhibit A as “good receiver” may have adequate linearity

Exhibit A also demonstrates the performance of an “excellent” receiver, twice as linear as a “good” receiver. Should the FCC mandate, after consultation with set manufacturers, a minimum linearity for DTV receivers, that value would probably exceed the value of the “good” receiver analyzed in Exhibit A.

Without adding mandated minimum linearity performance to DTV receivers, maximum spectral efficiency in the DTV band will not materialize.

## **6. THE COMMISSION SHOULD MANDATE SNR-CONTROLLED AGC FOR DTV RECEIVERS**

DTV set manufacturers have their cake, courtesy of the Advanced Television Systems Committee and the Federal Communications Commission, and they eat it. As members of the ATSC, the set manufacturers participated in writing their own minimal and voluntary DTV receiver (A/74) “guidelines.” The FCC further helped by not setting any performance standards for the receivers. Whatever merit there was years ago for not setting minimal receiver standards, it should be reconsidered if the priority is to create a new, functional and reliable, spectrally efficient DTV band.

Modern DTV receivers have a “tuner on a chip.” The chip is inexpensive and fits in small devices. But the chip does away with the tracking filter that insulates the desired channel from undesired channels<sup>4</sup>. In today’s environment, DTV channels are sparsely spaced and such chips have performed passably. That will no longer be the case if DTV channels are to be packed contiguously.

The DTV broadcasters and the public must be protected against the loss of deliverable payload due to the invisible interference generated by the inevitable

---

<sup>3</sup> Triple beats interference was ignored in Exhibit A, but as demonstrated in Exhibit A, sufficiently linear receiver with SNR-controlled AGC can adequately operate in a contiguous DTV channels band subject to all 3<sup>rd</sup> order interference products.

<sup>4</sup> The filter must contain inductors that cannot be integrated into a silicon chip.

receiver non-linearity. This can be accomplished by replacing the standard AGC circuit in the receiver with SNR-controlled AGC as shown and explained in Exhibit A.

## **7. THE COMMISSION SHOULD ALLOW DTV BROADCASTERS TO EXPERIMENT WITH VARIOUS MODULATIONS AND TRANSMISSION FORMATS**

During the standard-setting deliberations, the few who raised doubts about the proposed ATSC DTV standard on valid technical grounds were ignored. Speed was critical to the adoption of an American standard despite international tests that proved it to be inferior to other options. After the transition to DTV the extent of the problem became public<sup>5</sup>.

By adopting the ATSC standard without allowing DTV broadcasters to experiment with modulation formats more suitable for the reliable delivery of video, audio and data in harsh environments, the FCC has blunted the effort to find a modulation format more suitable for consumers. There is no technical justification for this because experiments with new modulation formats that will not cause harmful interference to anyone can be designed and approved by the FCC.

It is now common knowledge that the existing ATSC standard is unsuitable for emerging systems for over-the-air delivery of DTV. The ATSC standard has been unsuitable from the outset. The ATSC is working on a new standard with no known timeline.

Contiguously packing the channels is not only feasible but an opportunity for DTV broadcasters to introduce a new, much needed standard, that would permit higher payload deliverable with graceful degradation up to the radio horizon. That is what the public expects the FCC to promote. Why not start by encouraging DTV stations to experiment with new modulation/compression formats<sup>6</sup>?

O. Bendov  
President  
TV Antenna Group

---

<sup>5</sup> The ATSC standard is inherently unable to suppress critical echoes that are prevalent in urban and suburban areas because it is based on a single-carrier modulation. All other DTV and broadband communications systems, worldwide, are based on multiple-carrier modulation, which is uniquely suitable for consumer environments. For a detailed analysis of the flaws inherent to the ATSC standard see:

“Why are the ATSC-8VSB and M/H Standards Fundamentally Unsuitable for Next Generation Television Broadcasting and How to Painlessly Transit to ATSC/OFDM Network.” Available at [www.tvantenna.tv](http://www.tvantenna.tv)

<sup>6</sup> The FCC allows self-interference by Distributed DTV Transmitters.

# EXHIBIT A

# Spectrally Efficient DTV Broadcasting

O. Bendov

## I. Introduction

Future generations of DTV broadcasting will have to operate more efficiently than the first generation. More efficient operation means reliable reception with graceful degradation by hand-held devices, maximized payload to the radio horizon, and an all-adjacent (contiguous) channels transmission network. Fulfilling these objectives requires a system approach to the design of a new transmitter network, a new receiver with minimum specified linearity and with SNR-controlled AGC, and a new DTV standard, a standard that is robust enough in an environment of harsh multipath and all adjacent channels.

The subjects of the new transmitter network and maximum payload delivery with graceful degradation were discussed in two earlier papers [1][2]. This paper addresses the configuration of spectrally efficient all-adjacent channels and the receiver requirement for reliable reception in such environment.

## II. Receiver Performance Degradation in All-adjacent Channels Environment

The major contributions to the loss of the receiver's performance are:

1. Third-order intermodulation (IM) and crossmodulation (XM) from all undesired channels entering the tuner.
2. Excessive in-channel IM and XM generated by a very strong desired channel.
3. Blocking (gain compression) caused by very strong undesired channels generating undesirable signals at the desired channel frequency.
4. Desensitizing caused by poor IF selectivity and LO sidebands.

The most severe degradations (1-3) are caused by the non-linearity of the active RF and IF stages, and all effectively raise the minimum required desired signal power and lower the post-decoder SNR.

Traditionally, a tracking filter, about 20MHz-wide, was placed in front the RF section and that filter would eliminate the undesired  $N \geq \pm 2$  channels,  $N$  being the desired channel. Because the tracking filter requires inductive elements it cannot be implemented on a silicon tuner chip, now common in modern wireless receivers. Thus, modern tuners on a chip have broadband input. It follows that in an environment of all-adjacent channels, all of which enter the RF section, a new receiver, highly linear over its dynamic range for all DTV channels is essential. The desired linearity cannot be achieved by traditional signal-driven AGC circuits, which aggravate the degradations when the total signal power of the undesired channels is strong and the desired channel signal is weak.

Naturally, the first line of defense has to be the incorporation of highly linear RF and IF stages AGC circuitry that optimizes the undesired and desired levels using post-decoder SNR (or BER) as a metric. Why such optimization is necessary will be shown in Section IV using SNR loss contours.

Figures 1a and 1b show how the maximum available post-decoder SNR, the transmitter's SNR, typically 32dB,

Figure 1a: Receiver Post-decoder SNR Conours (2dB interval)  
Tx SNR=32dB ; Good Receiver ( $IP_3=16\text{dBm}$ )

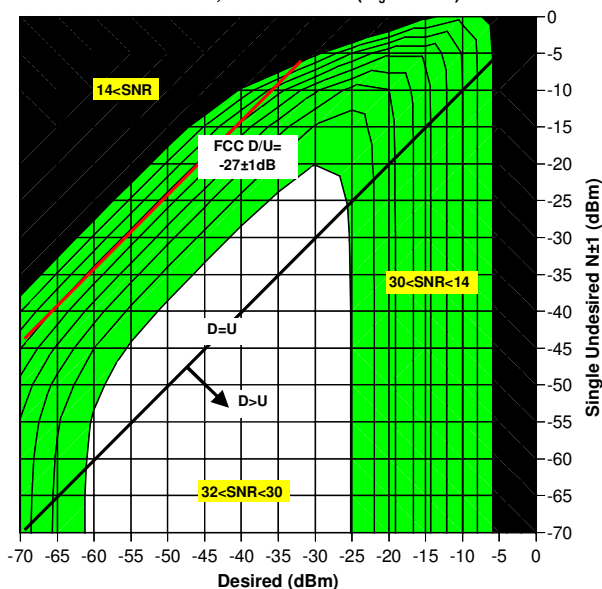
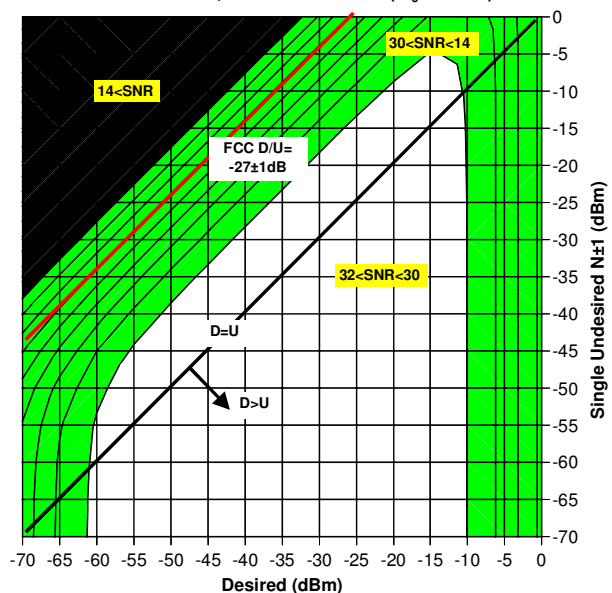

Figure 1b: Receiver Post-decoder SNR Conours (2dB interval)  
Tx SNR=32dB ; Excellent Receiver ( $IP_3=32\text{dBm}$ )



is degraded by the desired channel (N) when the undesired is a single first-adjacent channel ( $N=\pm 1$ ). The calculated loss of SNR of the desired channel, assuming no multipath, follows the method developed in an earlier paper [3]. Within the white area, the post detection SNR loss would be  $\leq 2$  dB. Within the black area, the SNR loss would be  $\geq 18$  dB. Ideally, programmable attenuators would adjust the gain of the RF/IF sections such that the desired and undesired levels are within the optimum operating white area, and out of the unacceptable black area.

The range of the desired (D) and undesired (U) levels that bound the optimum white operating area depends on the linearity of the RF/IF sections. Figure 1a is for a “good” receiver and Figure 1b is for an “excellent” receiver. In this context, “good” means that without adjacent channel interference the desired level can reach  $-6$  dBm before the receiver’s SNR drops 18 dB from 32 dB to 14 dB, whereas “excellent” means that when the desired level is 0 dBm the receiver’s SNR drops only 8 dB from 32 dB to 24 dB. If the linearity of two receivers could be defined by a 3<sup>rd</sup> Intercept Point ( $IP_3$ ), the “good” would be equivalent to  $IP_3=16$  dBm and “excellent” equivalent to  $IP_3=32$  dBm.

The measured power of the D channel = D + noise + interference and its measured SNR = D / (noise + interference). The D power can then be solved from these equations. The D power can also be estimated from the average amplitude of the D’s pilot(s). The U power can then be determined from a lookup table since D and its SNR are known.

Figure 1 highlights the desirable range of the received D and U power ranges at the receiver for a single-adjacent channels operation. For a minimum loss of SNR this range should be between  $-25$  dB and  $-55$  dB. Figure 1 also shows that the FCC’s fixed D/U protection ratio, based on transmitted powers, fails for strong and weak received signals and is marginally close to the cliff-edge elsewhere, leaving little SNR margin for multipath and other interference.

Figure 2 shows the scheme for SNR-controlled AGC. Once the transmission parameter signaling (TPS) is decoded and the pilots synchronized, the D’s power and its SNR can be estimated and the RF and IF gains adjusted by two programmable attenuators<sup>a</sup>.

As shown in Figure 2, the RF gain control moves U+D diagonally across Figure 1 and the IF gain control moves D horizontally across Figure 1. Therefore, the white operating area could be reached for most (but not all) levels of D and subject to adjacent channel interference.

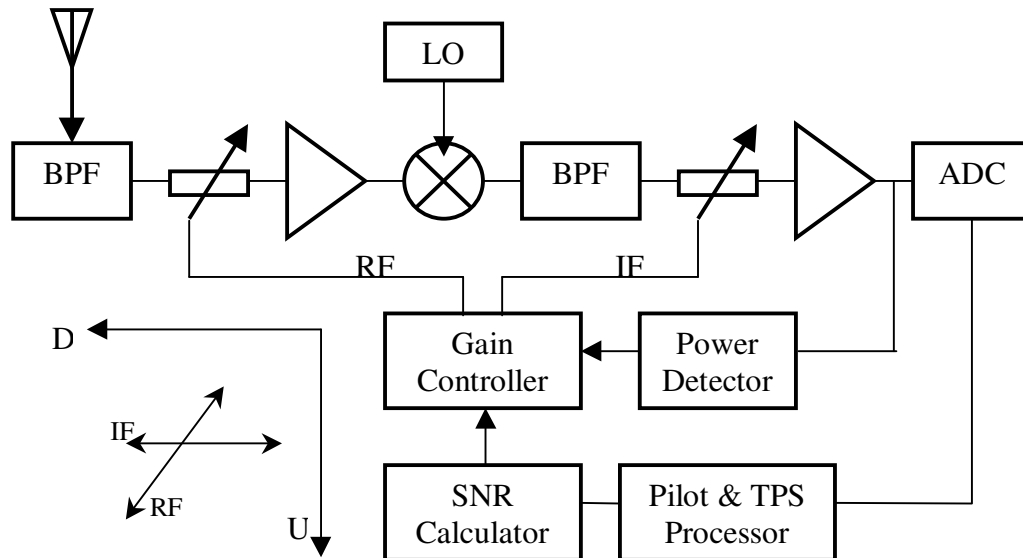

Figure 2: Modified AGC for Adjacent Channel Reception Optimization

The relative levels of the desired and undesired signals at the input to the receiver are generally unknown. When D is very weak or very strong or if D+U is very strong the SNR measure may be unavailable. Those extreme conditions refer to the black areas in Figure 1. However, the power detector provides a measure of D+U. In those extreme situations, the Gain Controller must, based on the detected U+D, decide whether the RF or IF gain should be first adjusted, and by how much, in order to regain SNR data. If U+D is very weak, then D is presumed weak and the IF gain must be increased first. If U+D is very strong then the RF gain must be first decreased.

<sup>a</sup> It should be clear that Figure 2 is an entirely different scheme from traditional AGC control circuits.



### III. Spectrum Allocation for All-Adjacent Channels DTV Broadcasting

For most TV markets in the U.S., 16 full-power DTV stations (“Mains”) are sufficient to satisfy commercial and educational broadcasting. Eight LPTV channels (“Auxiliaries”), each shared by two adjacent Main stations, can be optionally located away from the Main channels. The Auxiliary channels would extend the range of the higher payload, thus improving the Quality of Service (QoS) contours of Main stations up to the radio horizon (RH). Beyond the radio horizons, which act as terrain shielding against cochannel interference of inter-market Main-Main and intra-market Aux-Aux, there is no service. The QoS contours are distinct from the Noise-Limited Contours (NLC) in that the NLC normally extends the incident field strength “coverage” well beyond the Main’s RH regardless of actual reception. In this paper, the only interference that must be controlled is the interference inside the RH of the Main and Auxiliary channels.

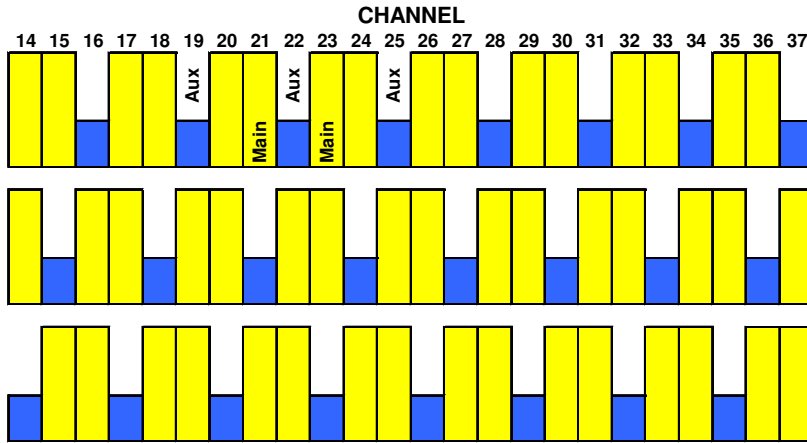

Figure 3: Potential Assignments of 16 Main and 8 Auxiliary Channels in a Market

multimultiplexing at low power levels. The interference and the resulting post-decoder SNR of these allocations is documented in the Appendix.

### IV. Transmitter Network with Ideal, Perfectly Linear Receivers

Figure 4 is an example of the proposed network, assuming no interference and an ideal, perfectly linear receiver [2]. The Main and Auxiliary antennas are presumed to serve several channels each, and for simplicity, have identical contours for channels multiplexed on the same antenna. More than one Main tower is permitted but only one is shown in Figure 4. Although only one Auxiliary transmitter is shown, several can be distributed around the periphery so long as the RH mutually shield against cochannel interference. The RH of the Main antenna is 71km and that of the Auxiliary antenna, 29km. The number of equal Auxiliary towers that can be placed without intersection of their RH can be derived from:

$$N = \frac{\pi}{\sin^{-1}\left(\frac{r_h}{R_H - r_h}\right)}$$

where  $R_H$  is the radius to the Main’s RH and  $r_h$  is the radius to the Aux’s RH. As long as there is no overlap of the RHs, the same channels can be used in multiple Auxiliary facilities since the RH acts as terrain shield. If RH intersection is unavoidable, cochannel auxiliary stations can be configured as a Single Frequency Network.

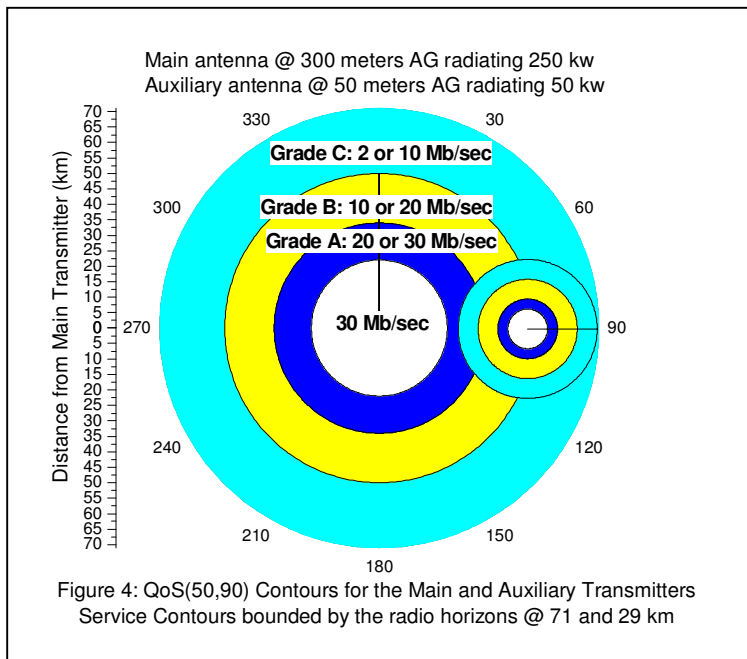

Figure 4: QoS(50,90) Contours for the Main and Auxiliary Transmitters Service Contours bounded by the radio horizons @ 71 and 29 km

Figure 4 is based on a model of no external interference and an ideal receiver. This model is and has been used for channel allocation and for estimating coverage contours. What distinguishes actual service contours from coverage contours is the inclusion of interference, a realistic rather than ideal receiver, setting the RH as the limit for reliable reception, adding SNR margin for multipath and incorporating graceful degradation to minimize the “cliff-edge” effect. Service, as defined by post-decoder SNR and deliverable payload contours with realistic receivers and subject to external interference is addressed next.

### V. Post-decoder SNR Contours of the Contiguous 18 Full-power and 8 LPTV Stations

In this section, the interference analysis developed in the Appendix is applied to the desired Main-23 and Aux-22 in the presence of the undesired transmissions on channels 14-37. Figure 5 shows the expected post-decoder SNR contours of Main-23 between its Eastern and Western RHs. For the example shown in Figure A4 of

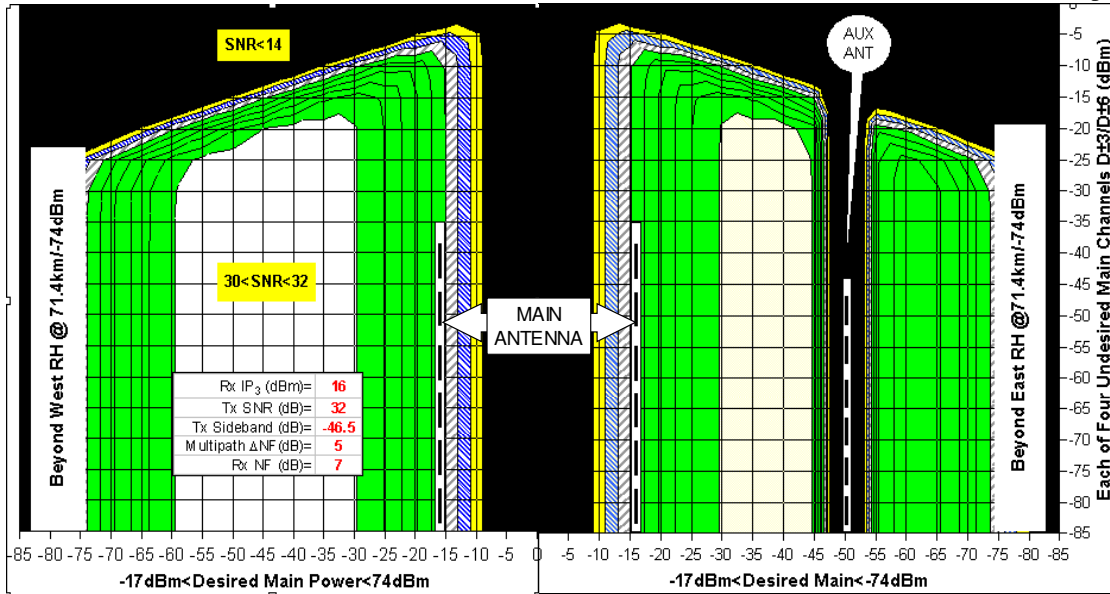

Figure 5: Post-decoder SNR Contours (2dB intervals) of Main-23  
F(50,90) ; Rx Antenna @ 30feet AG

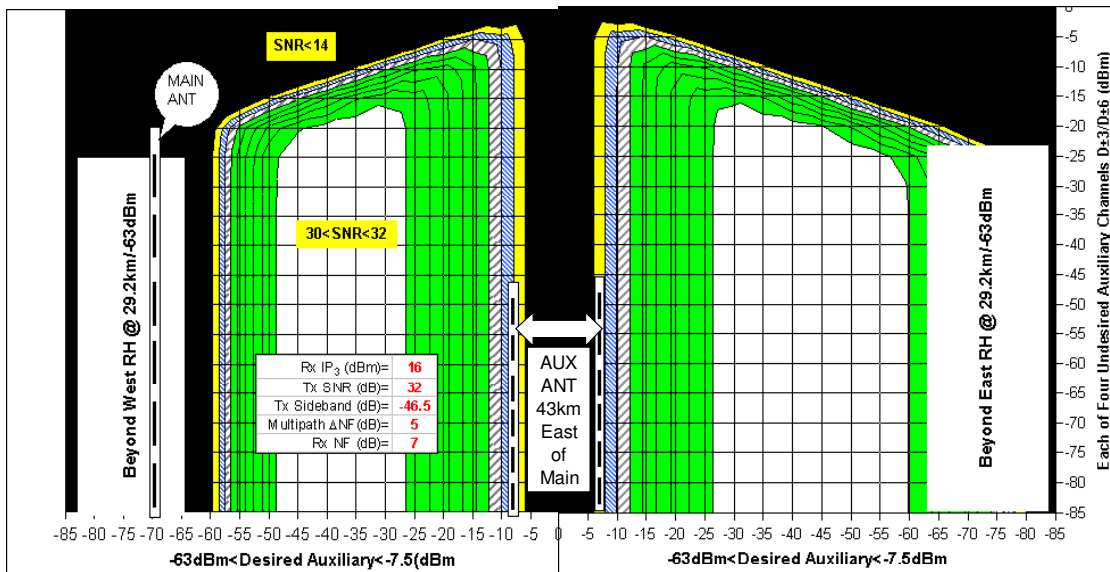

Figure 6: Post-decoder SNR Contours (2dB intervals) of Auxiliary-22  
F(50,90) ; Rx Antenna @ 30feet AG

SNR (and payload or throughput) from the base of the transmitting antenna to its RH.

<sup>b</sup> In this example the ERP of Main-23, 250kW, was arbitrarily set at 6dB below the maximum authorized 1000kW.

the Appendix, the received power varies from -17dBm near the transmitting antenna to -74dBm at the RH<sup>b</sup>. Without the Aux, the SNR contours toward the Eastern RH (Figure 5) would be identical to those toward the Western RH. Near the Main-23 transmitting antenna and at each RH, the expected SNR is 20dB. So even without SNR-controlled AGC, the SNR is adequate based on rooftop antenna, F(50,90) propagation, 5dB allowance for multipath noise and a “good” receiver. Optimization with the SNR-controlled AGC could raise the SNR to as high as 30dB. In reality, F(50,90) and rooftop antennas are optimistic and some margin for tower separation between the desired and the undesired, about 1dB/km separation would be desirable.

For hand-held devices in a harsh terrain, a more linear receiver, also within current state-of-the art, would be the ultimate answer to an improved

When the adjacent LPTV channel, Aux-22 (Appendix Figure A4), is added such that its RH is bounded by the RH of Main-23, its strong signal creates a loss of SNR for Main-23 and this loss is most pronounced near the Aux-22 transmitting antenna. But, as shown in Figure 6, in that region and up to the Eastern RH, the receiver can switch to the same broadcast at half rate on the higher SNR of Aux-23. The system designer may choose a directional antenna for Aux-22 instead of the omnidirectional antenna to improve the SNR of Main-23 near Aux-23.

The importance of the receiver's linearity to the reliable reception of contiguous TV channels cannot be over-emphasized. This is shown in Figures 7 and 8, where the receiver was changed from "good" ( $IP_3=16$ ) to "excellent" ( $IP_3=32$ ).

### Conclusions

First adjacent DTV channel stations already operate in some TV markets and these stations are only limited by a transmission power ratio  $D/U=-27\pm 1$  dB, which was determined experimentally and does not apply to high U power or to high and low D.

This paper shows that, based on post-decoder SNR analysis, all-adjacent channels transmission network, composed of full-power and LPTV stations, is feasible provided some mandatory specifications are imposed on DTV receivers. The required mandatory specifications are sensitivity, linearity and SNR-controlled AGC.

The proposed channel allocation, together with the proposed SNR-controlled AGC, would be a win-win for all. DTV broadcasters will get more bandwidth allowing for higher payload (throughput) to hand-held devices up to the RH, set manufacturers who will be able to manufacture integrated tuners on a silicon chip, and the FCC will be able to reallocate former DTV channels 38-51 to other

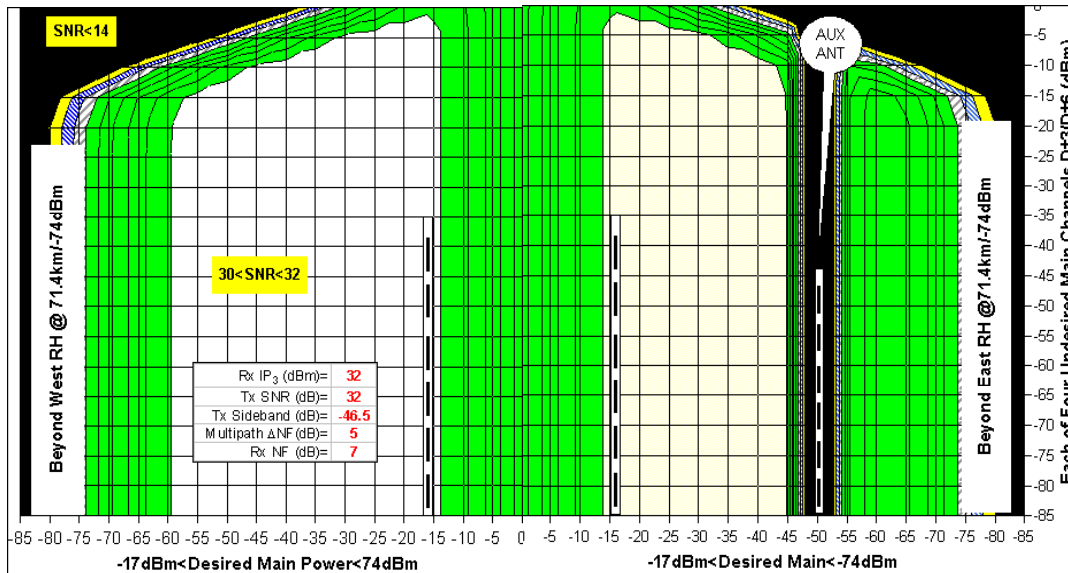

Figure 7: Post-decoder SNR Contours (2dB intervals) of Main-23  
F(50,90) ; Rx Antenna @ 30feet AG ; Rx  $IP_3=32$ dBm

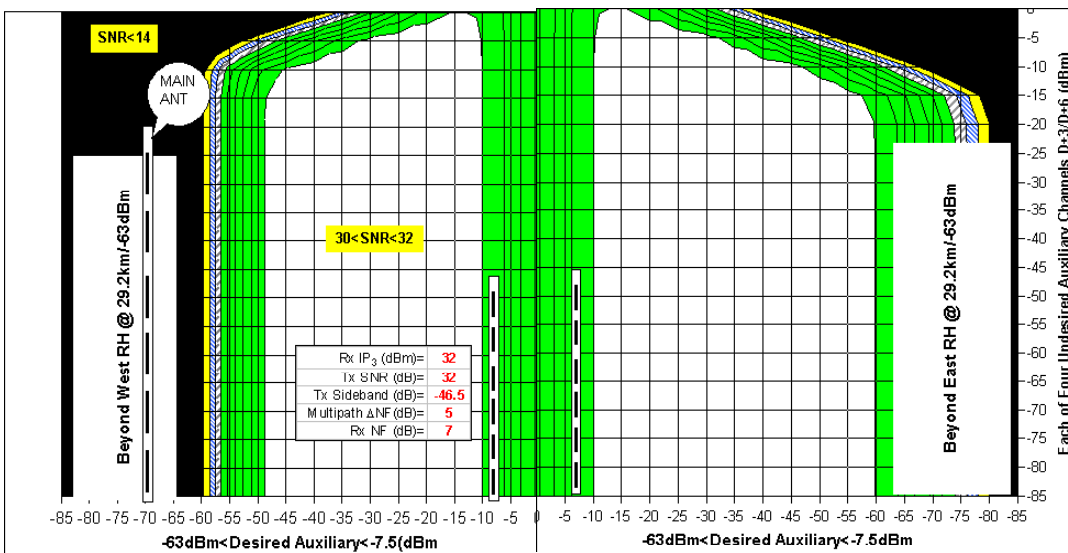

Figure 8: Post-decoder SNR Contours (2dB intervals) of Auxiliary-22  
F(50,90) ; Rx Antenna @ 30feet AG ; Rx  $IP_3=32$  dBm

services. Although a new DTV standard is not required, it would provide graceful degradation and reliable reception up to the RH. A distinction is made between the maximum service contour, which is limited by the RH and the coverage contour<sup>c</sup>, limited by the thermal noise of an ideal receiver. The coverage contour usually extends well beyond the RH where no reception with practical consumer devices is available and where residual interference is thus irrelevant.

<sup>c</sup> Noise-limited contours are based on an ideal receiver model subject to propagation algorithms that underestimate actual path loss and the heavy diffraction loss at the RH.

In the real world some loss of receiver sensitivity due to receiver non-linearity is inevitable and acceptable so long as enough signal power is available to the receiver. In the example shown in the Appendix, the received power does not fall below -63dBm with the Auxiliary transmitter, and -74dBm without it. There is thus at least an 11dB margin for loss of sensitivity due to interference assuming current converter boxes with -85dBm sensitivity.

Except for a few “triple beats,” excluded from the Appendix, the analysis of the expected SNR (Figures 5-8) is comprehensive. Adding the few “triple beats,” for the shown channel allocation<sup>d</sup> will not materially affect the results and conclusion of this paper.

### Appendix: 3<sup>rd</sup> order Interference

This analysis of the 3<sup>rd</sup> order interference generated by the receiver is based on the allocation shown in Section IV with equal ERP by any two adjacent Main channels, multiplexed on the same antenna. The channel’s spectrum is assumed flat and rectangular. The received power magnitude depends on the antennas’ radiation patterns and propagation paths, and may vary over the dynamic range of the receiver, but is assumed equal for the pair of adjacent Main channels.

As was shown earlier in Figure 1 for a single  $U=D\pm 1$ , as long as  $D \geq U$  and  $D$  is not too strong, the post-decoder SNR, when AGC-controlled, would be sufficiently high for reliable reception even in the presence of multipath. For  $N$  adjacent channels 14-37 allocated as shown in Section III, other modes of interference must be analyzed. A unique, albeit unlikely, mode is for all 24 channels enter the front-end of the receiver with equal power<sup>e</sup>.

The total 3<sup>rd</sup> order interference generated at the receiver in the  $D$  channel by  $N$  adjacent, equal power channels with rectangular shaped spectrum is [3]:

$$XM = 6NP_0^2 10^{-IP_3/10} + 9N^2 P_0^3 10^{-IP_3/5}$$

$$IM = 4N^2 P_0^3 10^{-IP_3/5}$$

$$IMXM = IM + XM = 6NP_0^2 10^{-IP_3/10} + 13N^2 P_0^3 10^{-IP_3/5} \quad (A1)$$

where  $P_0$  is the received power of each  $U$  channel.

As shown in Figure A1, as long as the received power is adjusted to  $-60\text{dBm} \leq P_0 \leq -40\text{dBm}$ , the post-decoder SNR  $\geq 30\text{dB}$ . That means that if all seven channels VHF 7-13 were multiplexed with equal ERP on one antenna or on two equal, collocated antennas, decoding each channel with the aid of SNR-controlled AGC would be possible.

Figure A1: Post-decoder SNR Contours for 1-24 Adjacent, Equal Received Power, Channels 14-37 ; “Good Receiver” ( $IP_3=16$ )

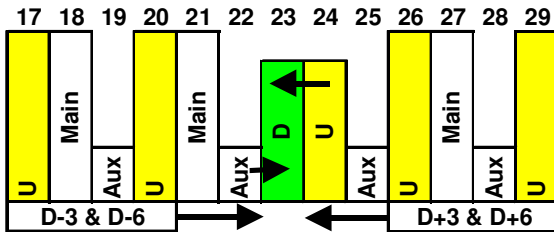
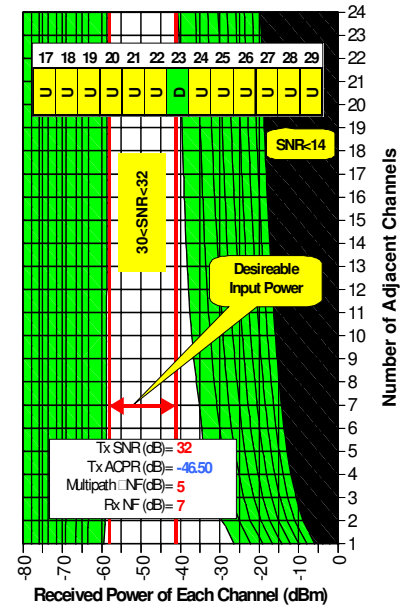

Figure A2: Interference into the Desired Main Channel by 1st Adjacent Channels and Two Pairs of Main Channels

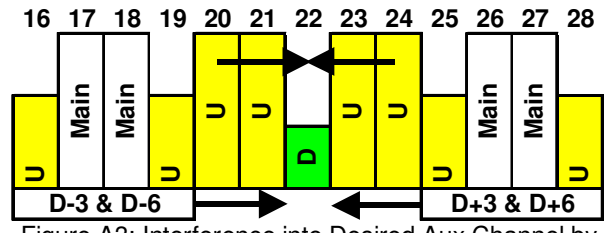

Figure A3: Interference into Desired Aux Channel by Two Pairs of Main Channels and Two Pairs of Aux Channels

The more likely and more adverse interference occurs when the received power of  $U$  and  $D$  channels are unequal. In such situations, the interfering pairs  $D\pm 3/D\pm 6$  and  $D\pm 1/D\pm 2$  must be considered as shown in Figures A2 and A3. Figures A2 and A3 show the  $D$  channels, Main-23 and Aux-22, with their sources of external interference, the  $U$  channels. The adjacent Auxiliary, channel 22, transmits the two Main channels, 23 and 24, at half rate each. The receiver tunes to the same program on either channel 23 or channel 22 depending on the local post-decoder SNR.

<sup>d</sup> For example, the triplet Main-20/23/26 will generate beats in Main-14/32/34.

<sup>e</sup> Typical of able TV systems.

To assist with the interference analysis, the distance from the Main tower to its RH, the limit of service area, is divided into two. In Figure A4, the region where the Undesired Auxiliary's power  $U <$  Main's power  $D$  is defined by:

$$K_A(\text{dB}) = U_A(\text{dBm}) - D_M(\text{dBm}) < 0$$

The region where the Undesired Main's power  $D <$  Auxiliary's power  $U$  is defined by:

$$K_M(\text{dB}) = U_M(\text{dBm}) - D_A(\text{dBm}) < 0$$

Figure A4: Received Power of Main Channel 23 and Auxiliary Channel 22  
F(50,90) ; Rx Antenna gain at Tuner=6dBd

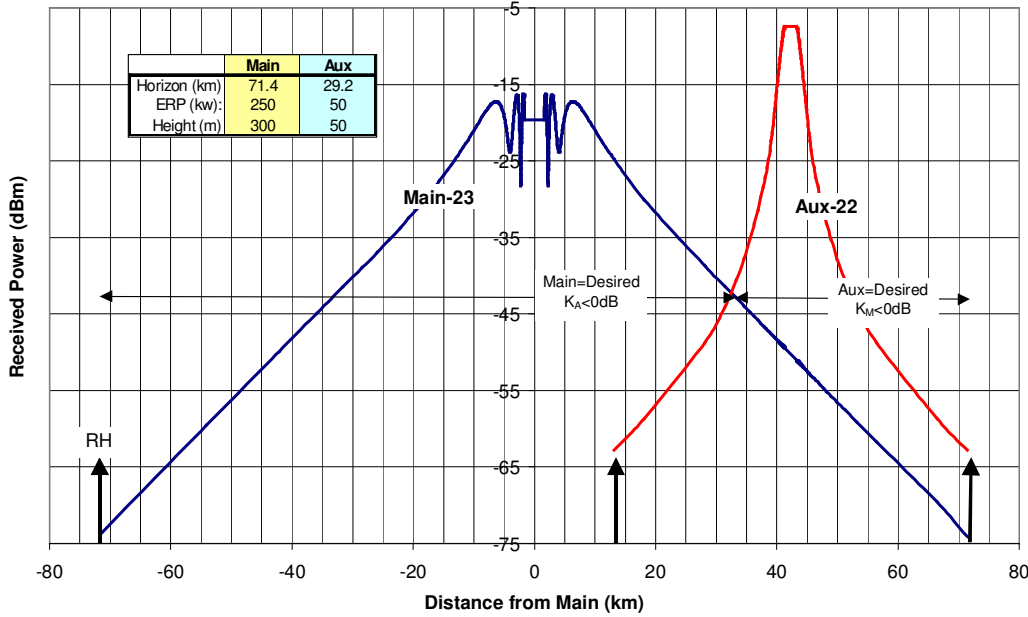
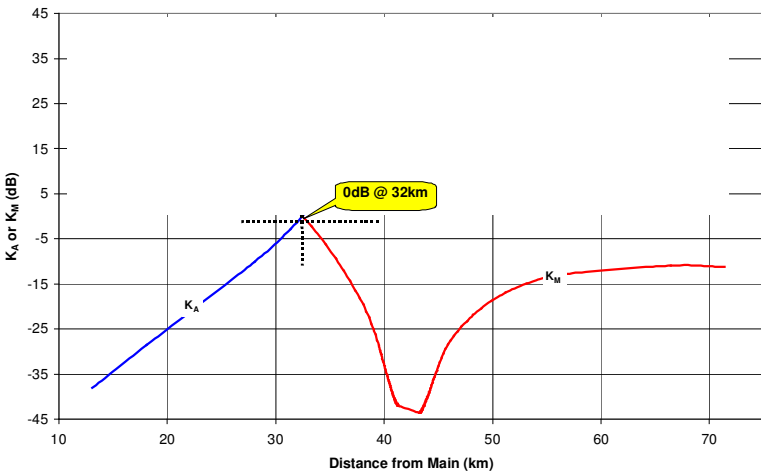

Figure A5: The Factors  $K_A$  and  $K_M$



$K_A$  and  $K_M$ , shown in Figure A5, are functions of the Main-Aux separation distance. The distance to crossover point,  $K_A = K_M = 0\text{dB}$ , is controlled by the radiation patterns, the antennas' height and the ERP of each station. If the Auxiliary uses a directional antenna, the crossover point will move further toward the RH of the Main. The receiver's switches between the Main and Auxiliary channels depending on the higher SNR of these two desired channels.

The interference power into the D Main-23 is the sum of six components, the first two generated at the Main and Aux transmitters and the last four generated at the receiver:

1. D-23 own transmitter's noise:

$$T_{xM} = \frac{D_M}{\text{SNR}_{T_x}} \quad (\text{A2})$$

2. Transmitter sidebands of U-24 and U-22:

$$T_{xSB} = (1 + k_A)\alpha D_M \quad (\text{A3})$$

$$k_A = 10^{K_A/10} \quad K_A \text{ in dB} \quad \alpha = 10^{-46.5/10}$$

3. 3<sup>rd</sup> order cochannel generated at the Rx by D-23 and U-24:

$$IM_{XM} = 12D_M^2 10^{-IP_3/10} + 52D_M^3 10^{-IP_3/5} \quad (\text{A4})$$

4. Sideband of U-23:

$$AC_{SB} = (k_A D_M)^3 10^{-IP_3/5} \quad (\text{A5})$$

5. Virtual cochannel by the pairs  $D \pm 3/D \pm 6$

$$[4]: IM_{PAIR} = 8U_M^3 10^{-IP_3/5} \text{ each pair} \quad (\text{A6})$$

6. Receiver thermal noise including multipath noise:

$$n_t (\text{dBm}) = -106.2 + NF(\text{dB}) + \Delta NF \quad (\text{A7})$$

Combining equation (A2)-(A7), the post

decoder SNR of Main-23 is:

$$\text{SNR}_M = \frac{D_M}{T_{xM} + n_t + (1 + k_A)\alpha D_M + 12D_M^2 10^{-IP_3/10} + (52 + k_A^3)D_M^3 10^{-IP_3/5} + 16U_M^3 10^{-IP_3/5}} \quad (\text{A8})$$

Not all ERPs of the Main channels need be equal and  $k_A$  can be  $> 1$  ( $K_A > 0\text{dB}$ ).

The interference power into the D Aux-22 is the sum of six components, the first two generated at the Main and Aux transmitters and the last four generated at the receiver:

1. D-22 own transmitter's noise:  $T_{xA} = \frac{D_A}{SNR_{Tx}}$  (A8)

2. Transmitter sidebands of U-21 and U-23:  $Tx_{SB} = k_M \alpha D_M$  (A3)

$$k_A = 10^{K_A/10} \quad K_A \text{ in dB} \quad \alpha = 10^{-46.5/10}$$

3. 3<sup>rd</sup> order cochannel generated at the Rx by D-22:  $IMXM = 6D_A^2 10^{-IP_3/10} + 13D_A^3 10^{-IP_3/5}$  (A10)

4. Sidebands of the pairs U-20/21 and U-23/24 [4]:  $AC_{SB} = 14(k_M D_A)^3 10^{-IP_3/5}$  (A11)

5. Virtual cochannel by the pairs D $\pm$ 3/D $\pm$ 6:  $IM_{PAIR} = 8U_A^3 10^{-IP_3/5}$  each pair (A12)

6. Receiver thermal noise including multipath noise:  $n_t(\text{dBm}) = -106.2 + NF(\text{dB}) + \Delta NF$  (A13)

Combining equation (A8)-(A13), the post-decoder SNR is:

$$SNR_A = \frac{D_A}{T_{xA} + n_t + 2k_M \alpha D_M + 6D_A^2 10^{-IP_3/10} + (13 + 14k_M) D_A^3 10^{-IP_3/5} + 16U_A^3 10^{-IP_3/5}} \quad (A14)$$

Where the Aux signal is much stronger than the Main's, the interference will be less than calculated by (A13) because there would be essentially no 1<sup>st</sup> AC interference ( $k_M=0$ ), and the external interference will be limited to that generated by D $\pm$ 3/D $\pm$ 6.

Clearly,  $SNR_M$  and  $SNR_A$  are highly dependent on the received powers,  $U_M$  and  $U_A$ , of the pairs D $\pm$ 3/D $\pm$ 6 relative to the desired powers  $D_M$  and  $D_A$ .

## References

- [1] O. Bendov, "UHF Digital TV Broadcasting Using Variable Payload for Delivery of Graceful Degradation of Service Throughout the Coverage Area," [www.tvantenna.tv/papers.asp](http://www.tvantenna.tv/papers.asp), April 2012.
- [2] O. Bendov, "Maximizing Payload Efficiency of Digital Television Broadcasting," [www.tvantenna.tv/papers.asp](http://www.tvantenna.tv/papers.asp), August 2012.
- [3] O. Bendov, "Interference to DTTV Reception by First Adjacent Channels," IEEE Transactions on Broadcasting, March 2005. Can be downloaded from [www.tvantenna.tv/papers.asp](http://www.tvantenna.tv/papers.asp)
- [4] O. Bendov, "Limits on Fixed Broadband Devices for Interference-free Operation in the DTV Spectrum," IEEE Transactions on Broadcasting December 2007. Can be downloaded from [www.tvantenna.tv/papers.asp](http://www.tvantenna.tv/papers.asp)